

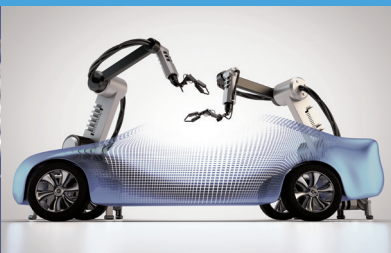

AF COMPRESSORS

6 ▶ 15 BAR OIL FREE AIR PISTON COMPRESSORS

NEW
▶ OPC
Range

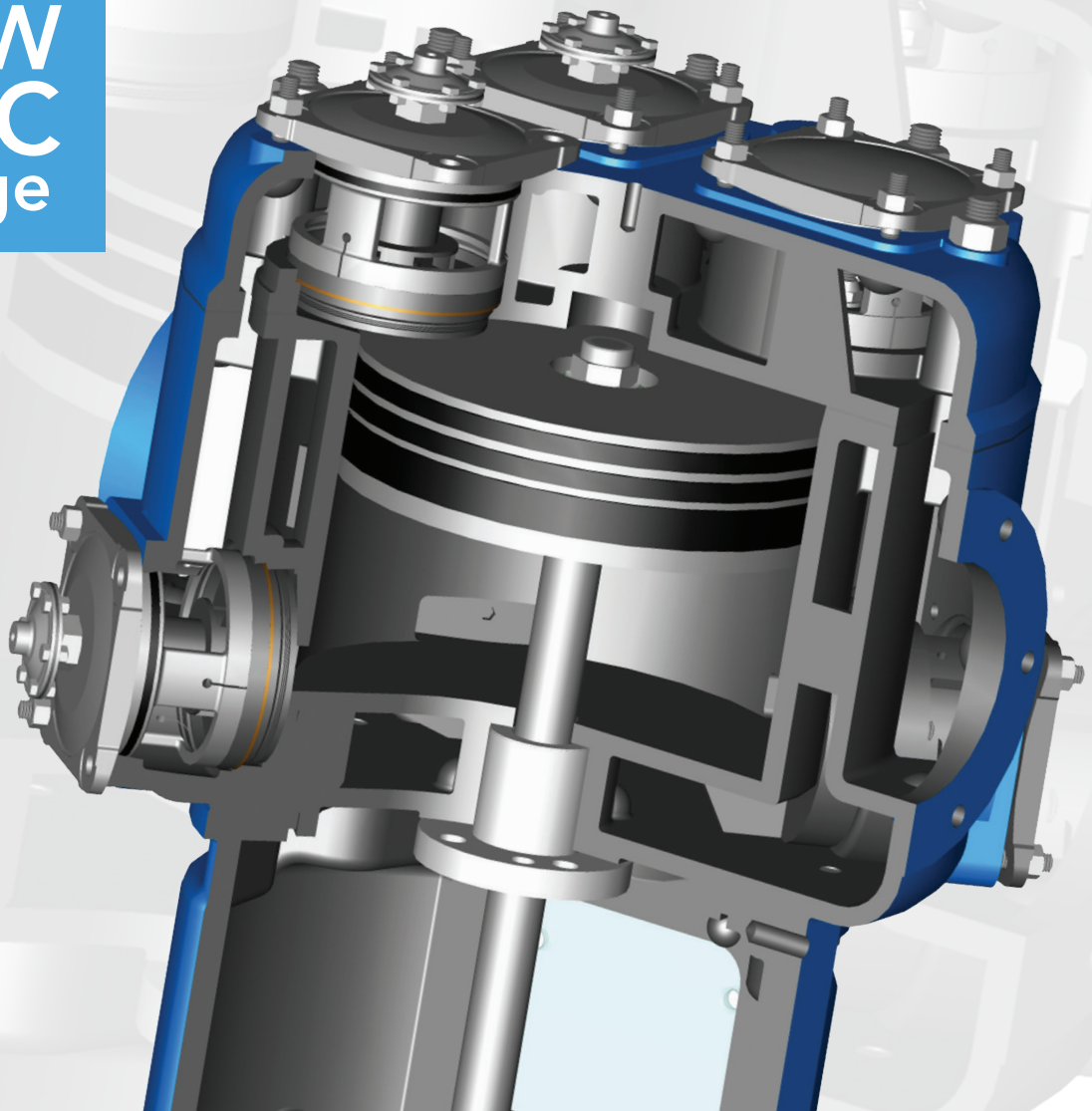

WWW.AFCOMPRESSORS.COM



2 STAGE OIL FREE PISTON COMPRESSORS

OPC RANGE: A COMPLETE RANGE OF LOW PRESSURE OIL-FREE PISTON COMPRESSORS SUITABLE TO THE FOOD & BEVERAGE INDUSTRY, PHARMACEUTICALS, CHEMICALS AND AUTOMOTIVE INDUSTRY.

OPC COMPRESSORS ARE SUITABLE TO THE MOST STRINGENT SITE CONDITIONS.

Model 8 bar 116 Psi	Capacity m ³ /min	Capacity CFM	Motor Power kW Service factor 1,0
OPC 45 - 8	7,7	272	45
OPC 55 - 8	9,5	335	55
OPC 75 - 8	12,8	452	75
OPC 90 - 8	14,2	501	90
OPC 132 - 8	22,5	794	132
OPC 160 - 8	27,1	957	160
OPC 200 - 8	32,1	1133	200
OPC 280 - 8	47,1	1663	280
OPC 315 - 8	53,0	1872	315
OPC 355 - 8	54,5	1925	355

Model 10 bar 145 Psi	Capacity m ³ /min	Capacity CFM	Motor Power kW Service factor 1,0
OPC 45 - 10	7,2	254	45
OPC 55 - 10	8,8	318	55
OPC 75 - 10	12,1	427	75
OPC 90 - 10	12,7	448	90
OPC 132 - 10	20,7	731	132
OPC 160 - 10	24,2	854	160
OPC 200 - 10	29,7	1048	200
OPC 280 - 10	42,7	1508	280
OPC 315 - 10	48,0	1695	315
OPC 355 - 10	54	1907	355

Capacity in FAD according to ISO 1217-2009. Motor power service factor 1,0.
Optimum air quality 8573-1.4.1 or 2.4.1, class 0 compliant. Technical modification without prior notice.
Any other capacity up to 15 bar / 217 Psi are available on request. sales@afcompressors.com

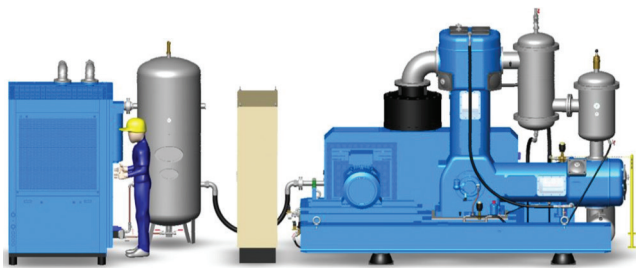

▶ Easy install and operate



Turnkey package:

- Additional final separator
- Air receivers
- Adsorption & refrigerative air dryer
- All filtration level available.
- Separate cooling systems.
- Protection for any site conditions
- Electrical Options, CE or UL Approval
- CE-PED, ASME, SELO... any certification available.

▶ Easy maintenance + low cost operation cost



Energy savings:

- AFS: Adjustable air Flow System
- SIS: Smart Inverter Starter.
Starting Current never exceeding Nominal current.
- Frequency inverter system
- Compressor management system.



A COMPLETE RANGE OF OIL FREE PISTON COMPRESSORS 6 BAR TO 15 BAR



LOWEST MAINTENANCE COSTS • LOWEST ENERGY COSTS • FEWEST MOVING PARTS • LOWEST SPEED

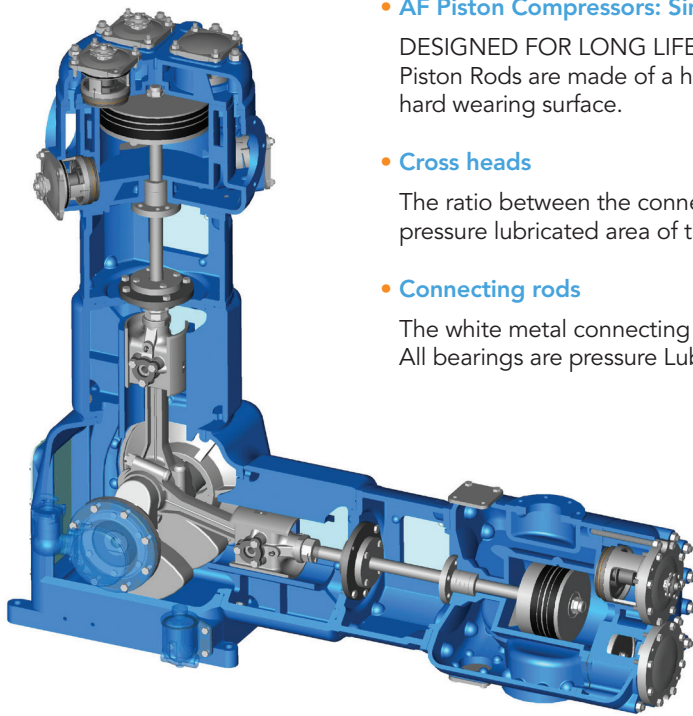

- **AF Piston Compressors: Simple and Robust**

DESIGNED FOR LONG LIFE and RELIABILITY

Piston Rods are made of a high resilient stainless steel and chromium plated to provide a hard wearing surface.

- **Cross heads**

The ratio between the connecting rod length and crank radius (nearly 5) and the large pressure lubricated area of the crosshead and guides ensures optimum life.

- **Connecting rods**

The white metal connecting rod main bearings are inherently long life items. All bearings are pressure Lubricated by a gear driven pump.

- **Crankshaft**

Is supported by two self-aligning bearings having two rows of generously dimensioned rollers to ensure perfect alignment. Counterweights attached to the crankshaft provide excellent balance. Rotational speeds range between only 400 and 750 rpm.

ENERGY, PERFORMANCE AND OPERATING COSTS : PISTON IS STILL THE BEST !

- **Features**

- Simplistic design as the '40bar AF compressor', 2 stage, oil free, Robustness, long-lasting efficiency.
- Slow speed, fewer parts, less wear, long lasting and reliable technology.

- **Benefits**

BEST ENERGY Efficiency vs. SCREW AND CENTRIFUGAL UNITS !

- Direct money savings. Low costs for maintenance, Lower. Energy Consumption short and long term pay back.
- EASY and SIMPLE Mechanics to Maintain
- Rapid Return on Investment.
- Long lasting performance and low cost use compared to other systems.

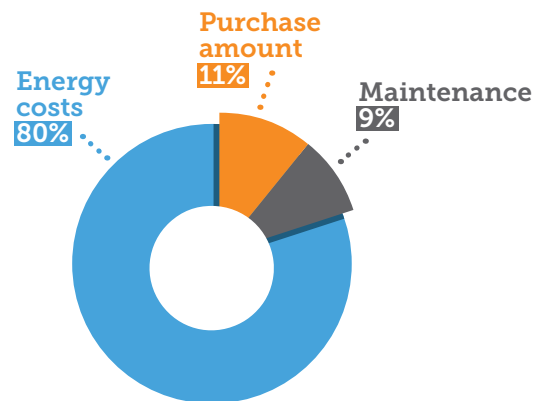

Total life cycle of a 40 bar Pet compressor calculated on a 10 year operation.





THE OIL FREE PISTON COMPRESSORS SPECIALIST OPERATING WORLDWIDE

THE MOST EFFECTIVE SERVICE NETWORK IN THE WORLD FOR OIL FREE RECIPROCATING AIR COMPRESSORS.

AF's Aftermarket & Service team actively assists you in the maintenance and optimization of your compressor to ensure decades of high performance and trouble free operation.

All parts and components available for immediate dispatch : 100% availability of your compressed air installation is our main and daily objective!

GLOBAL SERVICE: COMPLETE NETWORK

3 Production sites: Liège - Belgium / Kunshan - China / Puna - India.

14 Subsidiaries with local spare parts centers:

- More than 20 AF agencies: spares and technical support
- 2 distributions centers: Europe + Middle East

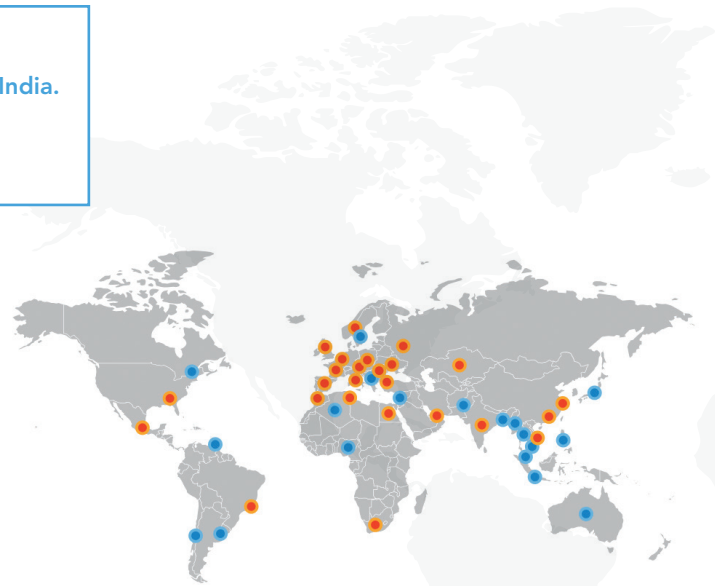

Visit our website to get all updated contacts details of:

- AF subsidiaries, local commercial & technical support worldwide
- AF official agencies, with local service support

▶ IN EXCESS OF 5600 UNITS IN OVER 170 COUNTRIES

Algeria	Indonesia	Serbia
Argentina	Kazakhstan	South Africa
Australia	Lebanon	South Korea
Austria	Luxembourg	Spain
Bangladesh	Malaysia	Sweden
Belgium	Mexico	Switzerland
Brazil	Morocco	Thailand
Canada	Myanmar	Trinidad & Tobago
Chile	Nigeria	Tunisia
China	Norway	Turkey
Czech Republic	Pakistan	UAE-Dubai
Egypt	Peru	Ukraine
Finland	Philippines	United Kingdom
France	Poland	USA
Germany	Romania	Vietnam
India	Russia	



A GROWING TEAM AT YOUR SERVICE...

- More than 150 specialized technicians.
- Spare Parts Centers For Immediate Parts availability.
- Technical experts to provide high level support over the phone or at the customer's site.
- Multilingual & local service support.
- Key account management, area managers, technical experts on line and in each subsidiary.
- 24/7: round the clock service worldwide and hotline: +32 4239 9660.
- More than 5600 units: AF compressors operating worldwide in over 170 countries .



WWW.AFCOMPRESSORS.COM

Head Office Commercial Department:

Tel. +352 26 95 66 34

Sales@afcompressors.com

All contacts worldwide on: www.afcompressors.com

