



AF COMPRESSORS

40 BAR OIL FREE PET COMPRESSORS

- FLEXIBLE SOLUTIONS
- TURN KEY INSTALLATIONS
- THE BEST SERVICE WORLDWIDE
- THE LOWEST COSTS
- ENERGY SAVINGS



www.afcompressors.com



■ **INNOVATION AND TRADITION**
IN COMPRESSED AIR INDUSTRY SINCE 1870



■ **WORLDWIDE ORGANISATION**

Ateliers François s.a. - AF Compressors
AF Main factory is located in Liege Belgium.

AF 'Sister company for the After Sales Head Office and Major Spares Shop separate from the factory is 100% dedicated to the after sales activity.

CSP S.A. in Alleur / Liege Belgium

AF SUBSIDIARIES ENSURES Local Commercial and technical support with local SPARES SHOPS, local technicians. AF MEXICO, AF MIDDLE EAST, AF SHANGHAI, AFUSA, AFRUS, AF POLAND, AF TURKEY, AFINDIA...

AF AGENCIES are 100% trained for the 40 bar air piston compressors. They also ensure local SPARES available on their local market.

The Philippines, Greece, Argentina, Algeria, Lebanon...

Our customers and references are most renown blow moulder manufacturers, Engineering offices, the mineral, spring and drinking water providers as well as the major soft drinks producers...

Juices, breweries, edible oil, milk, and all other existing PET applications, FOOD or Non Food industries.

■ **See our contacts worldwide on www.afcompressors.com**

■ **Experience's heritage in compressed air since 1870.**

AF, a privately owned company was formed in Liège in 1870, to produce pneumatic hammers used for tunnelling in the local mining industry. In the early 1900's we were manufacturing reciprocating compressors for the coal industry. During the decades that followed, our company continued to develop its heavy duty compressors especially for the steel industry. After 1960 when Ateliers François SA was formed, a range of oil free reciprocating compressors with PTFE piston rings was developed and successfully used in the brewing, chemical and food industries.

With the emergence of the PET industry in the early 1980's along with a constant Research & Development philosophy, and thanks to our numerous subsidiaries, our customers are today benefiting of all this experience in 135 different countries throughout the world.





CE6 - CE46b installations

■ **The 40 bar Piston oil Free compressor packages.**

Turn-key installations.
Complete solutions for worldwide operation.
Features and Benefits

■ **High Efficiency.**

Full Range of 40 Bar PET Compressors.
Low pressure and boosters solutions.

■ **The lowest costs.**

Lowest installation and maintenance costs
Lowest energy costs.

■ **Available options for worldwide conditions.**

■ **Global Solutions :** Variable Speed, Intelligent Softwares...

■ **The best Service worldwide.**

Worldwide presence and specialized assistance.
Spare parts and flexible maintenance packages.

■ **Unlimited Warranty Extension Program.**

THE 40 BAR PET COMPRESSOR



Air dryer

FEATURES

Stainless steel flexible connections from the galvanized air receiver to the 40 bar air dryer.

Stainless steel dryer with integrated 1 micron filter, dew point alarm and automatic Bekomat drain system.

BENEFITS

Highest quality 40 bar air available in the entire PET market.

Constant PET Production : Return on Investment.

Best availability of PET Production time.



Control cabinet

FEATURES

A starting and capacity control cabinet fully interconnected with the compressor, with microprocessor adaptable to PC monitoring.

BENEFITS

Easy control and monitoring,

Integrated monitoring of the whole package.

Safe and securing control for the whole package.

Capability of Network priority selections.

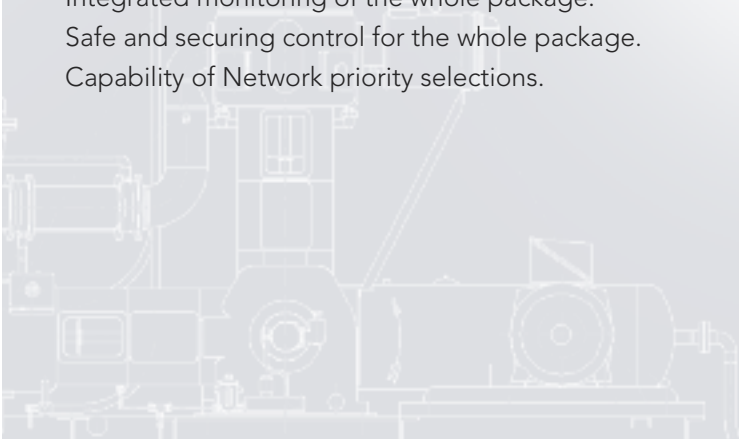



■ **Bare unit**

FEATURES

Robust and simple design : easy accessibility to the machine.

Skid mounted on antivibration mounts.

Stainless steel valves.

Bekomat automatic draining systems on the whole unit.

BENEFITS

Low installation costs, no specific foundation.

Easy and quick installation.

Easy and quick maintenance.

Low maintenance costs.

Longest lifetime of all components and spares.



■ **Air receiver (vertical or horizontal)**

FEATURES

Hot galvanised 40 bar Air Receiver.

Equipped with Bekomat drain system.

BENEFITS

Air receiver with top quality 40 bar air.

To the 40 bar air Dryer.



■ COMPRESSOR OPTIONS :
THE GLOBAL SOLUTION



■ Compressor options THE GLOBAL SOLUTION

Radiator cooling systems, complete solutions with water pump.
For maximum ambient temperatures up to 32°C.
Automatic spray systems – option.

Evaporative Cooling Towers, all wetbulb temp. selections.

Every cooling system is designed to match with the most stringent ambient conditions from tropical environment to Siberia.

40 Bar Air Dryer options : stainless steel condenser,
water cooled or air-cooled. Dew Point Alarm,
integrated pre-filter. Standard or Stainless Steel condenser - option.

Options for the 40 Bar air receiver :

Every Codes and certifications EC-PED, SLQLO, ASME...

On the compressor crankcase, oil warming or oil cooler.

Pre-lubrication pump foreseen with the optional Soft Starter or VSD



■ Specific equipment options.

Air-conditioning for electrical control cabinet.

40 bar active carbon filter with 40 bar shut off gate.

■ Also available :

Set of spare parts for 1st. necessity, non return valve,
condensate drain collectors.

Electric device : Soft starters, all voltages and frequencies available.

Specific electric cabling, pneumatic connections,
IP 55 motors, special colours...



■ COMPRESSOR OPTIONS :
ENERGY SAVINGS



■ **Frequency inverter.
Variable Speed Drive.**

Following to your specific project, the frequency inverter can increase the relative efficiency and decreases the power consumption. A pre-lubrication pump, a specific motor and other special safety device is proposed suiting to your technical requirements (harmonic filters panels...)

■ **Energy Savings optional equipment :
Air Back 5 Re-Injection System.**

This Re-injection - recycling system allows the simple 40 bar AF Compressor to re-use the 5 bar compressed air coming back from the Blow Moulding Machine. The 1st Stage is acting as a Low Pressure unit while the 2nd and 3rd stage are managed as a Booster unit. Two machines in one. The energy saving is from 7 to 9 kWh per 100 m³/H retrofit. This a unique system on the whole High Pressure PET market. Designed and Engineered by AF.

■ **Intelligent monitoring : Priority Selection XC-2-12.**

Managing from 2 to 12 units, with same or different installed power. With star delta, soft starter or Frequency Inverters. Controlling several units in parallel for an optimal performance and energy saving. Constant air pressure in the network. The compressors are monitored to anticipate - or not - the rapid pressure changes. Intelligent data analyser, performance monitoring. Optimal running hours timing and control.

Other possibilities to integrate additional and optional computer monitoring...



■ HIGH EFFICIENCY



Model	Capacity FAD m ³ /H	Capacity CFM	Speed rpm	Motor Power kW
MC 244	225	132	600	45
CE 2A	312	184	485	55
CE 2B	390	230	650	75
CE 24 A	510	300	570	90
CE 24 B	600	353	670	132
CE 46 XS	750	441	340	132
CE 46 S	870	512	400	160
CE 46 A	1080	636	500	200
CE 46 B	1320	777	500	250
CE 6	1700	999	425	315
CE 68 A	2100	1236	480	355
CE 68 S	2300	1354	460	400
CE 68 B	2600	1529	520	450
CE 68 BES	2600	1529	430	450
CE 680 A	2900	1706	480	500
CE 680 B	3200	1872	540	550

Low speed and low energy consumption

Complete 40 Bar range, capacities from 225 to 3200 m³/H and more...

■ Also available :

Full range of 2 stage oil free 7,8,10,13,15 bar reciprocating **AF** compressors flow from 400 to 2100 m³/H.

On request :

Boosters : inlet pressure 7,8,9,10 bar to outlet pressure 20,30,40 Bar, flow from 600 to 6000 m³/H.



CE68b installations

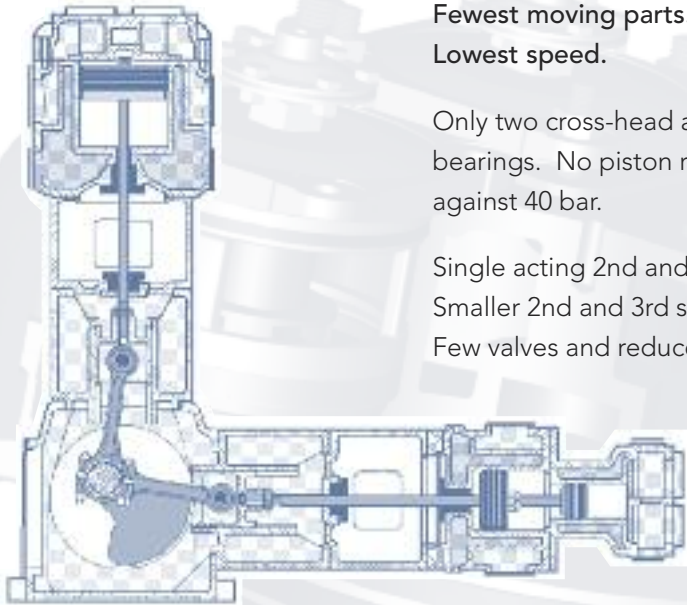

Lowest maintenance costs.

Lowest energy costs.

Fewest moving parts.

Lowest speed.

Only two cross-head assemblies, two connecting rods and associated bearings. No piston rod packing on 3rd stage, which eliminate sealing against 40 bar.

Single acting 2nd and 3rd stage, requiring few valves.

Smaller 2nd and 3rd stages horizontal to optimise the piston ring life.

Few valves and reduced energy losses.

High energy efficiency :

longer component life, less friction, low speed : 340 rpm to 670 rpm.

Less wearing parts as described above.

- Easy access on the machine for maintenance.
Reliability and easy maintenance.
Less time for maintenance, equals more
- Easy and quick installation due to the use of anti-vibration mounts, no specific foundation is required : low investment costs for installation.

■ **80 % of PET Plant working money expenses is energy consumption**

AF brings your production direct money savings !

Energy cost is increasing worldwide and neglecting its importance in a production management is for sure increasing the working expenses.

Money savings is your Benefit during years...

AF : The Lowest Energy Consumption

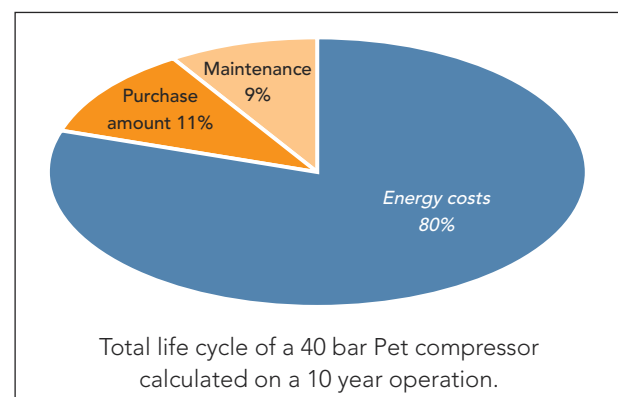

THE BEST 40 BAR
SERVICE WORLDWIDE !



ALL SPARES + COMPONENTS AVAILABLE ON STOCK
READY FOR DISPATCH

More than 3000 AF COMPRESSORS
in more than 135 countries !

SUBSIDIARIES AND TECHNICAL SUPPORT WORLDWIDE

GLOBAL SUPPLY LOCAL SUPPORT

More than 70 AF 40 BAR PET
SERVICE ENGINEERS WORLDWIDE

SUBSIDIARIES AND TECHNICAL SUPPORT WORLDWIDE





■ Unlimited Warranty Extension Program

THANKS TO THE ROBUST AND SIMPLE DESIGN AND THE PROVEN RELIABILITY OF THE AF "L" DESIGN

ON TOP OF THE STANDARD WARRANTY ON THE COMPRESSOR PACKAGE, AF ALSO OFFERS A LONGER WARRANTY ON THE MECHANICAL PART OF THE MACHINE. This warranty is of course subject to the respect of the Utilisation Guide and the Technical Manual.

Reducing costs ! Increasing productivity !

Maximum productivity & Return On Investment for your PET blowing line.

Prevention and organization is the key point of the efficiency for your installation !

Following to your planning, to your organization we do the maintenance. Result: less "urgency work", often linked with production loss, the contract offers a real advantage: all is planned and Your PET bottling productivity is optimised.

We take care and foresee your needs. The certainty of a long term Quality maintenance, a real specialized service in 40 Bar PET oil free piston compressors.

We manage and take care of your installation

■ Warranty !

The 40 Bar PET compressor can be under unlimited warranty... As long as the running unit is linked with a maintenance program.

Much more than the 40 bar PET specialist AF is the reliable partner!





AF COMPRESSORS

www.afcompressors.com



Visit our website to get updated contact details of our subsidiaries and official agencies, our commercial and technical supports worldwide.

PRINT : DIEU - BELGIUM +32 10 41 50 24



THE 40 BAR PET SPECIALIST
OPERATING WORLDWIDE

Ateliers François SA

274 Rue Côte d'Or ■ BE-4000 Liège - Belgium

Commercial Department:

Tel. + 352 26 95 66 29 ■ Fax + 352 26 95 66 66

central@afcompressors.com ■ www.afcompressors.com



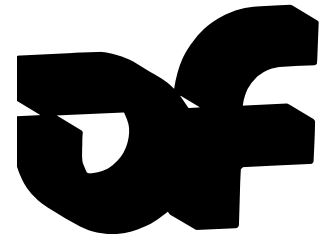

AF COMPRESSORS



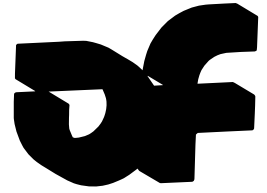

AF COMPRESSORS

www.afcompressors.com

